

GAME NO. 739
OCTOBER, 1978

MIDWAY'S SPACE INVADERS PARTS CATALOG



MIDWAY MFG. CO.

A BALLY COMPANY

10750 WEST GRAND AVENUE
FRANKLIN PARK, ILLINOIS 60131
U.S.A.

PHONE: (312) 451-1360 CABLE ADDRESS: MIDCO TELEX NO.: 72-1596

TABLE OF CONTENTS

	Page No.
GENERAL INSTRUCTIONS	1
SWITCH ADJUSTMENTS	2
NO. 739—SPACE INVADERS—PICTURE	3—5
FLUORESCENT FIXTURE ASSEMBLY	6—7
FRONT DOOR ASSEMBLY	8—9
TRANSFORMER BOARD ASSEMBLY	10—11
ADDITIONAL PARTS LIST	12
GAME BOARD COMPONENTS LAYOUT	13
MOTHER BOARD COMPONENTS LAYOUT	14
POWER SUPPLY COMPONENTS LAYOUT	15
POWER SUPPLY SCHEMATIC	16
MONITOR SCHEMATIC — (MOTOROLA)	17
MONITOR SCHEMATIC — (WELLS-GARDNER)	18
WELLS-GARDNER REPLACEMENT PARTS LIST	19—20

WARNING

THIS GAME MUST BE GROUNDED. FAILURE TO DO SO MAY RESULT IN DESTRUCTION TO ELECTRONIC COMPONENTS.

GENERAL INSTRUCTIONS FOR "SPACE INVADERS"

INSTALLATION:

1. Remove shipping cleats located on bottom of cabinet.
2. Install 4 provided leg levelers to bottom of cabinet and level cabinet.
3. The power is controlled by a switch located on top of the cabinet. Plug into A.C. only, 115 volts, 60 cycles. In low line areas (105 volts or less), a boost in the output voltage of the transformer may be obtained by removing the wire from the 115 volt tap of the transformer and rewiring it to the 105 volt position.

VOLTAGE CONTROL POTS:

Located on power supply board (P.C. A080-90400-F000) and are preset at the factory. These pots should not be tampered with unless the Distributor Service Department is contacted.

MASTER VOLUME CONTROL:

Located on game logic board (P.C. A084-90700-B739) controls the volume of all sounds and may be varied as desired by rotating pots.

ADJUSTMENT SWITCHES:

Located on game logic board (P.C. A084-90700-B739) and may be adjusted as indicated on separate instruction sheet in back box area.

1. No. of Missile Bases per game: Adjustable 3 to 6.
2. Bonus Missile Base: Awarded at 1,000 or 1,500 points.

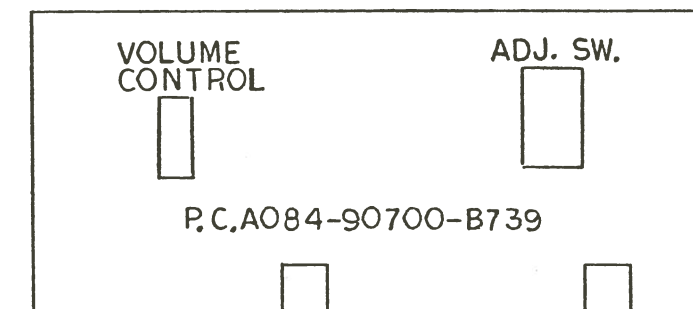

TO REMOVE CONTROL PANEL FOR SERVICE:

1. Open coin box door.
2. Unplug control panel jack located to the left of coin box opening.
3. Unlatch (2) clamps located on each side of cabinet.
4. Remove control panel for service.

ADJUSTMENT SWITCHES

		SW. 1
COIN INFORMATION DISPLAYED ON SCREEN	1 COIN, 1 PLAYER	ON
COIN INFORMATION IS NOT DISPLAYED ON SCREEN	2 COINS, 2 PLAYERS	OFF

BONUS MISSILE BASE

		SW. 2
BONUS BASE AWARDED AT 1000 PTS.		OFF
BONUS BASE AWARDED AT 1500 PTS.		ON

NUMBER OF BASES PER GAME

	SW. 3	SW. 4
3 BASES	ON	ON
4 BASES	ON	OFF
5 BASES	OFF	ON
6 BASES	OFF	OFF

*SWS 5, 6, 7 AND 8 ARE NOTUSED.

M051-00739-A010

NOTE – NO RAM AND ROM TEST

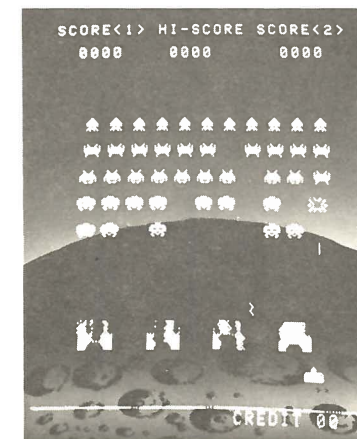
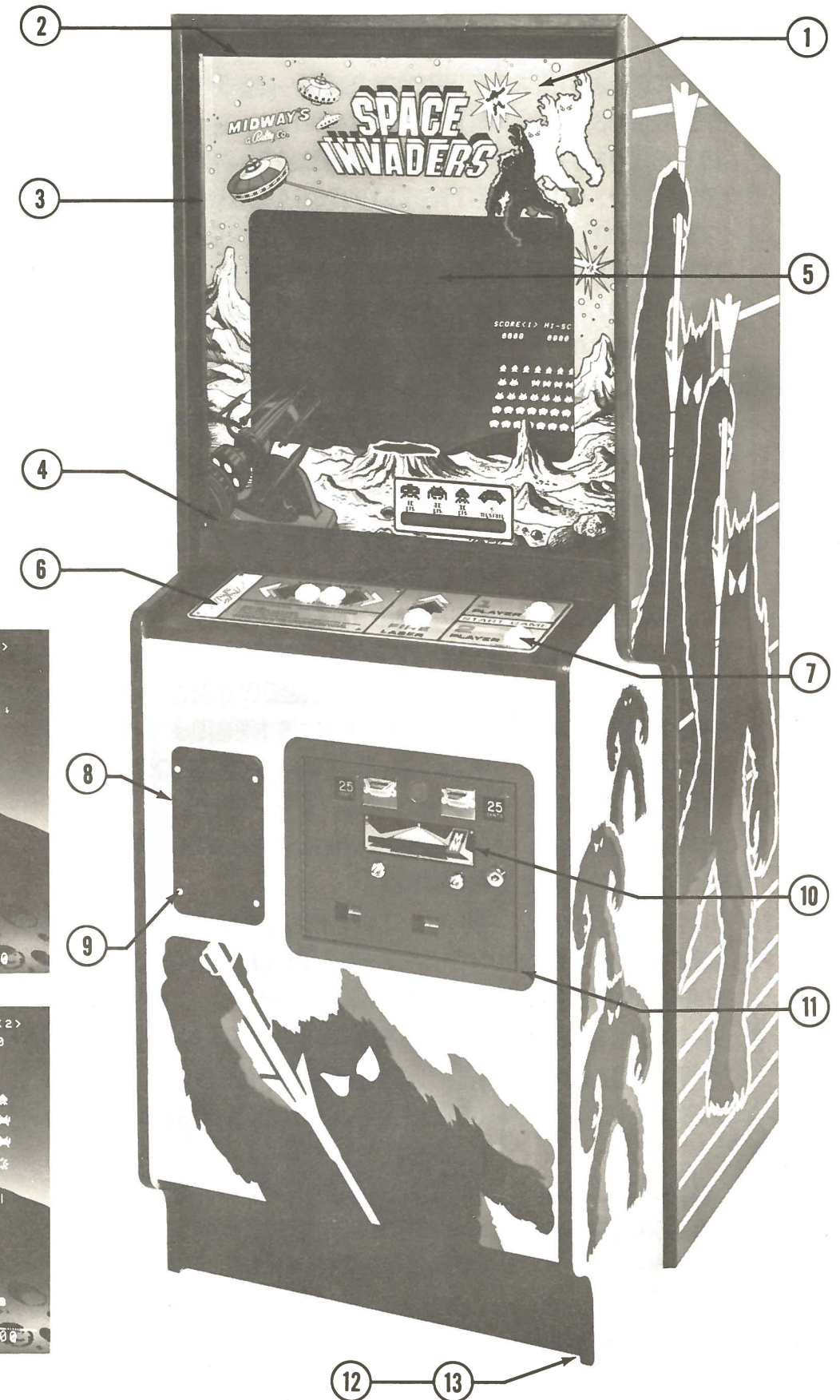

ORDER BY PART NUMBER ONLY

ITEM	PART NO	DESCRIPTION
1	0739-00903-01SC	DISPLAY PLEX - 26-5/16 x 24-7/8 x 3/16
2	0537-00903-0015	GLASS CHANNEL - 24-1/4" LG.
3	0537-00903-0011	GLASS CHANNEL - 26-1/4" LG. (2 REQ'D.)
4	0629-00902-0100	GLASS LIFT CHANNEL
5	0739-00900-00SC	BACKGROUND SCENERY CARD
6	0739-00904-00SC	DECORATIVE PLATE
	0017-00101-0639	#8-32 x 1-1/4 CARRIAGE BOLTS (4 REQ'D.)
	0017-00104-0022	#8 WASHER (4 REQ'D.)
	0017-00103-0061	#8-32 HEX LOCKNUT SEMS. (4 REQ'D.)
7	A739-00012-0000	PUSH BUTTON ASSY. (5 REQ'D.)
	0017-00009-0384	BUTTON (5 REQ'D.)
	0017-00009-0376	HOUSING (5 REQ'D.)
	0010-00593-0000	SPRING (5 REQ'D.)
	0017-00104-0028	FLAT WASHER (10 REQ'D.)
	0017-00100-0025	"E" RING (5 REQ'D.)
	0017-00103-0054	PAL NUT (5 REQ'D.)
	0586-00107-0000	MTG. BRKT. (5 REQ'D.)
	0586-00036-0000	SWITCH ASSY. (5 REQ'D.)
	0017-00101-0521	#5-40 x 3/8 R.H.M.S. (5 REQ'D.)
	0020-00202-0000	SWITCH PLATE (5 REQ'D.)
8	0017-00009-0393	SPEAKER GRILL & HARDWARE
	0017-00003-0187	SPEAKER
9	0017-00101-0642	#8-32 x 1-1/2 CARRIAGE BOLTS M.S. (4 REQ'D.)
10	A090-00020-02GR	DOUBLE ENTRY COIN DOOR ASSY.
11	A090-00002-02GR	COIN DOOR FRAME
	0017-00101-0555	#6-32 x 5/16 HEX HD. S.M.S. (3 REQ'D.)
12	0017-00102-0048	LEG LEVELERS (4 REQ'D.)
13	0017-00103-0026	LEG LEVELER NUTS (4 REQ'D.)
		<u>NOT SHOWN LIST</u>
	0017-00003-0164	19" CATHODE RAY TUBE (C.R.T.)
	0017-00003-0212	19" MONITOR CHASSIS
	0592-00104-0100	CHASSIS MTG. BRKT. - R.H.
	0592-00104-0200	CHASSIS MTG. BRKT. - L.H.
	0161-00100-0000	T.V. MTG. WASHER (4 REQ'D.)
	0017-00101-0639	#8-32 x 1-1/4 CARRIAGE BOLT (4 TUBE, 4 CHASSIS)

ORDER BY PART NUMBER ONLY

ITEM	PART NO	DESCRIPTION
	0017-00104-0022	#8 WASHER (4 TUBE, 4 CHASSIS)
	0017-00103-0061	#8-32 HEX LOCKNUT SEMS. (4 TUBE, 4 CHASSIS)
	0739-00902-0000	MIRROpane MIRROR 24-13/16 x 23-3/4 x 1/4
	0739-00502-0000	LOCKING CLEAT (2 REQ'D.)
	0017-00101-0028	#8 x 3/4 HEX. HD. WD. SCR. (4 REQ'D.)
	0739-00102-0000	GLASS LOCK BRKTS. (2 REQ'D.)
	0739-00906-0000	SCREEN OVERLAY
	0739-00905-0000	CARDBOARD BEZEL
	A739-00010-0000	DAG SPRING ASSY.
	3000-17155-0000	GROUND STRAP
	0080-00101-0000	FISHPAPER SHIELD
	0017-00009-0033	BASIC CLAMP (2 REQ'D.)
	A739-00007-0000	DISPLAY INSERT
	0017-00031-0002	SOCKETS (5 REQ'D.)
	0017-00003-0052	LAMPS (5 REQ'D.)
	0017-00041-0037	SPONGE RUBBER TAPE - 24" LG.
	0586-00036-0000	ON-OFF SWITCH
	0567-00106-0100	SWITCH MTG. PLATE
	0017-00101-0025	#8 x 1/2 SLOT. HEX. HD. WD. SCR. (4 REQ'D.)

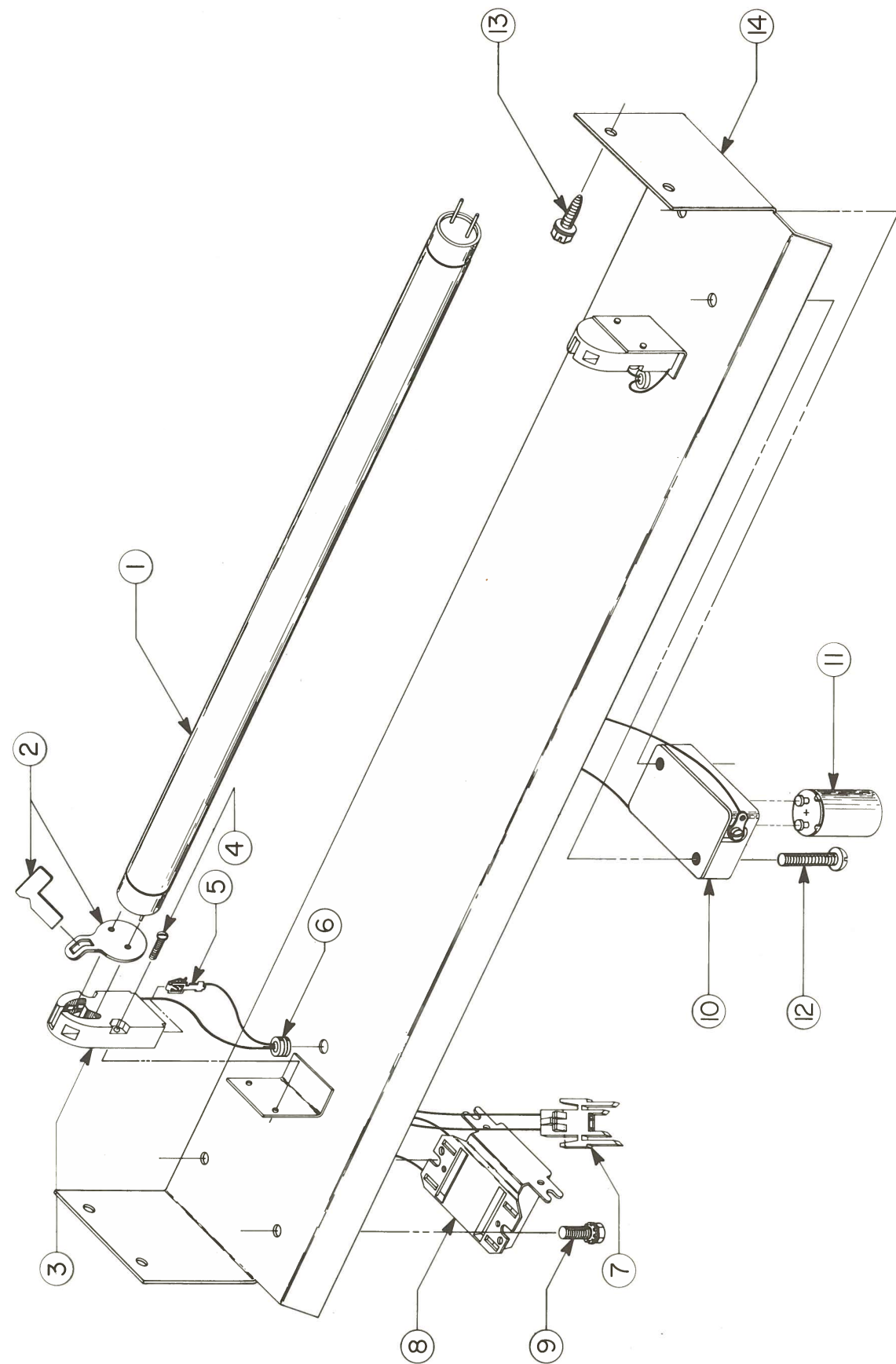

MIDWAY MFG. CO.
A BALLY COMPANY

ORDER BY PART NUMBER ONLY

ITEM	PART NO	DESCRIPTION
1	0017-00003-0046	18" FLUORESCENT LAMP (BLACK LIGHT)
2	0017-00021-0005	FLUORESCENT LOCKS (2 REQ'D.)
3	0017-00031-0015	LAMP HOLDERS (2 REQ'D.)
4	0017-00101-0521	#5 - 40 x 3/8 BINDER HD. M.S. (4 REQ'D.)
5	0017-00021-0078	BRASS FLUORESCENT TERM. (4 REQ'D.)
6	0017-00041-0013	GROMMETS (2 REQ'D.)
7	0017-00021-0096	2 TERMINAL JACK - FEMALE
8	0017-00003-0026	BALLAST
9	0017-00101-0593	#8-32 x 1/4 PAN HD. EXT. SEM. M.S. (2 REQ'D.)
10	0017-00021-0079	STARTER HOLDER
11	0017-00003-0019	STARTER
12	0017-00101-0528	#5-40 x 3/4 R.H.M.S. (2 REQ'D.)
13	0017-00101-0025	#8 x 1/2 HEX HD. WD. SCR. (4 REQ'D.)
14	A739-00015-0000	FLUORESCENT BRKT. WELDING ASSY.
		<u>NOT SHOWN LIST</u>
	0739-00901-00SC	PLANET ARTWORK
	0017-00101-0598	#8-32 x 5/16 HEX HD. S.T. M.S. (3 REQ'D.)

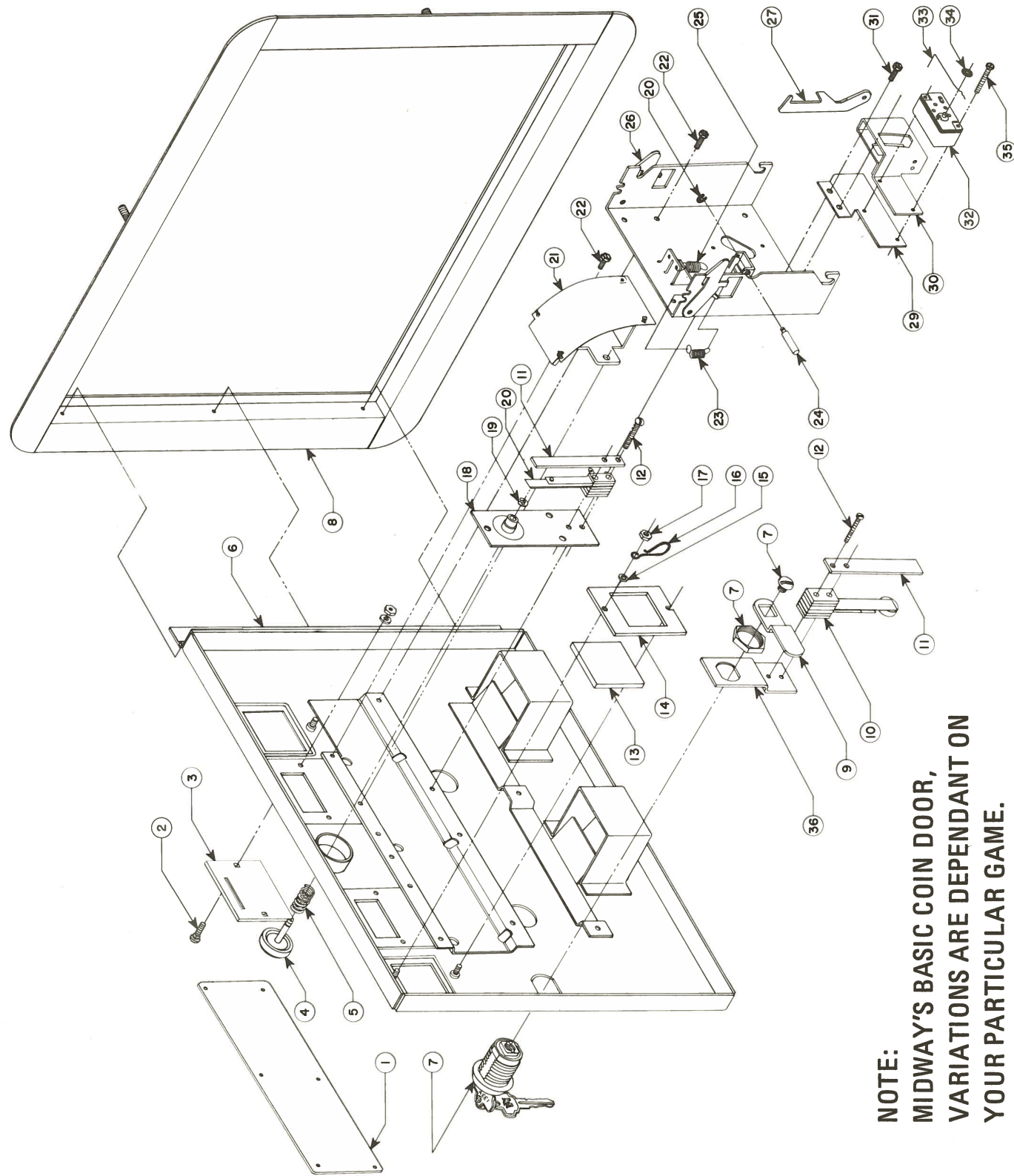

NOTE:
MIDWAY'S BASIC COIN DOOR,
VARIATIONS ARE DEPENDANT ON
YOUR PARTICULAR GAME.

ITEM	PART N ^o	DESCRIPTION
1	0090-00902-0000	DRESS PLATE
	0090-00902-0100	DRESS PLATE (W/O PRESS BUTTON TO START GAME)
2	0017-00101-0552	#6-32 x 1/4 CARRIAGE BOLT (2)
3	0090-00117-0300	COIN ENTRY PLATE (25¢)
4	0090-00906-0000	PLASTIC START BUTTON
5	0010-00007-0000	COMPRESSION SPRING
6	0090-00013-0200	DOOR ASSY. DOUBLE ENTRY
7	0017-00005-0050	DOOR LOCK & KEY WITH SCREW & NUT
8	0090-00002-02BR	DOUBLE DOOR FRAME
9	0017-00005-0041	421 N.S. CAM
10	0090-00901-0000	DOOR SWITCH
11	0090-00126-0100	SWITCH BACKUP PLATE
12	0017-00101-0528	#5-40 x 3/4" LNG. M.S.
13	0090-00903-0040	25¢ WINDOW
14	0090-00143-0000	COIN PLEX RETAINER
15	0017-00104-0002	SPLIT LOCK WASHER
16	0017-00007-0019	KEY HOOK
17	0017-00103-0005	#6-32 HEX NUT
18	0090-00010-0000	SW. PLATE & OILLITE ASSY.
19	0017-00100-0018	"E" RING
20	0090-00131-0000	SWITCH
21	0090-00104-0000	TOP & BTM. COIN CHUTE W/BRKT. ASSY.
22	0017-00101-0598	#8-32 x 5/16 SCREW
23	0010-00181-0100	SPRING
24	0090-00129-0000	PIVOT POST
25	0010-00134-0000	SPRING
26	0090-00008-0000	ACCEPTOR FRAME ASSY.
27	0093-00155-0000	REJECTOR LEVER
28	0017-00100-0012	"E" RING
29	0093-00151-0000	COIN GUIDE MTG. BRACKET
30	0090-00005-0000	COIN GUIDE ASSY.
31	0017-00101-0555	#6-32 x 5/16 SCREW
32	0017-00005-0039	COIN SWITCH
33	0010-00557-2500	TRIP WIRE
34	0017-00007-0132	PUSH-ON RING (BIK)
35	0017-00101-0507	#4-36 x 3/4 SCREW
36	0090-00128-0000	SWITCH BRKT. – DOOR TILT

NO. 739 – SPACE INVADERS – TRANSFORMER BOARD ASSY.

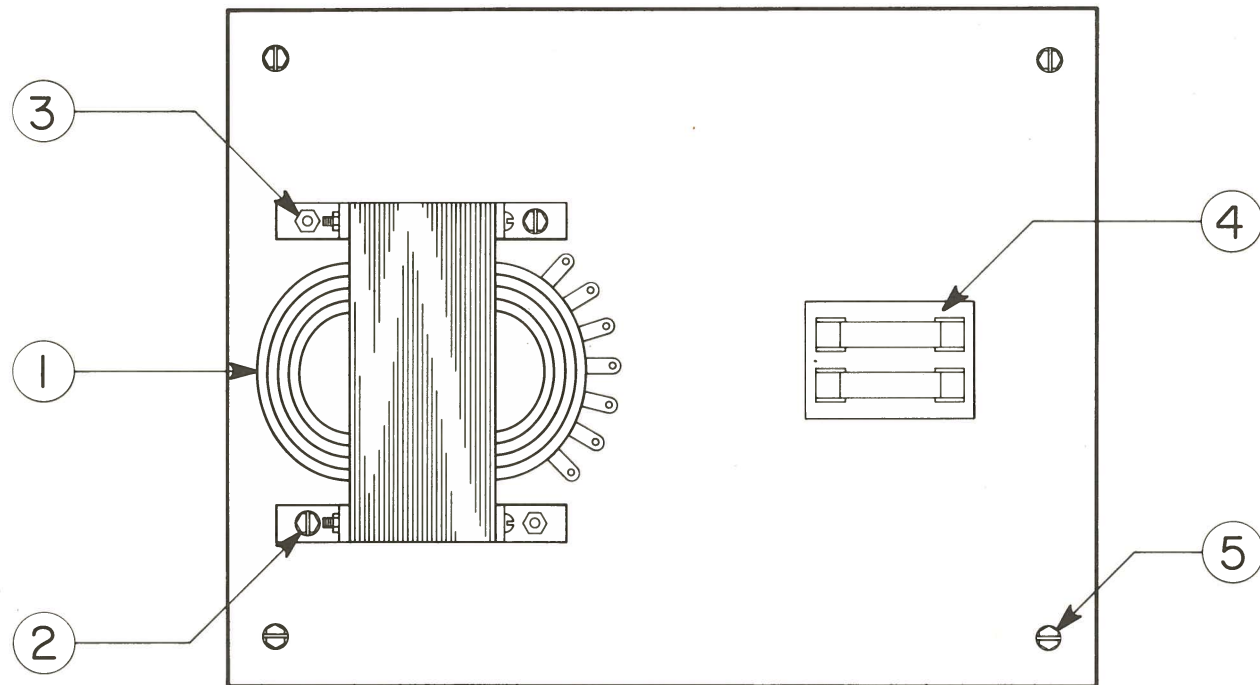

MIDWAY MFG. CO.
A BALLY COMPANY

NO. 739 – SPACE INVADERS – TRANSFORMER BOARD ASSY.

ORDER BY PART NUMBER ONLY

ITEM	PART N ^o	DESCRIPTION
1	MT00-00058-A000 MT00-00059-A000	TRANSFORMER – 60 CYCLE - OR - TRANSFORMER – 50 CYCLE – (FOREIGN)
2	0017-00101-0025	#8 x 1/2 SLOT. HEX HD. S.M.S. (2 REQ'D.)
3	0017-00101-0692 0017-00103-0008	#8-32 x 7/8 CARRIAGE BOLTS (2 REQ'D.) WITH #32 HEX NUT (2 REQ'D.)
4	0720-00001-0200	FUSE BLOCK ASSY. (2 POSITION)
5	0017-00101-0030 0017-00101-0017	#8 x 1" HEX HD. WD. SCREW (4 REQ'D.) #6 x 1/2 HEX HD. S.M.S. (4 REQ'D.)
		NOT SHOWN
	0017-00003-0064	LINE CORD – NOT SHOWN
	A630-00015-0000	TRANSFORMER BOARD ASSY. – COMPLETE

MIDWAY MFG. CO.
A BALLY COMPANY

NO. 739 - SPACE INVADERS - ADDITIONAL PARTS LIST

ORDER BY PART NUMBER ONLY

ITEM	PART NO	DESCRIPTION
	A739-00014-0000	LOWER BACK DOOR ASSY.
	A739-00013-0000	UPPER BACK DOOR ASSY.
	A097-00001-0000	LOCK ASSY. (1 UPPER, 1 LOWER)
	0618-00117-0000	VENT SCREEN (2 UPPER, 2 LOWER)
	A623-00110-0000	COIN BOX ASSY.
	A623-00013-0000	COIN BOX COVER ASSY.
	A624-00001-0000	COIN BOX GUIDE BRKT. ASSY.
	0624-00101-0000	COIN BOX GUIDE BRKT.
	0017-00101-0628	#8-32 x 3/4 CARRIAGE BOLTS (4 REQ'D.)
	0017-00104-0022	#8 STL. WASHER (4 REQ'D.)
	0017-00103-0061	#8-32 LOCKNUT SEMS. (4 REQ'D.)
	0017-00003-0102	COUNTER METER (MOUNTED ON COIN DOOR)
	M052-00190-0001	TRANSPARENT TAPE (ORANGE) - 13" x 1" WIDE
	0017-00009-0009	TURN BUTTONS (2 REQ'D.)
	0017-00101-0017	#6 x 1/2 HEX HD. BLK. WD. SCREW (2 REQ'D.)
	0603-00131-0000	STRIKE (2 REQ'D.)
	0017-00101-0028	#8 x 3/4 HEX HD. BLK. WD. SCR. (4 REQ'D.)
	0017-00003-0225	"CHEAT" INTERLOCK SWITCH
	0625-00133-00B0	INTERLOCK SW. MOUNTING BRKT.
	0017-00101-0028	#8 x 3/4 HEX HD. BLK. WD. SCR. (2 REQ'D.)
	A084-90700-B739	GAME BOARD ASSY.
	A084-90000-K000	MOTHER BOARD ASSY.
	A082-90400-F000	POWER SUPPLY ASSY.
	A630-00015-0000	TRANSFORMER BOARD ASSY.
	0597-00012-0100	P.C. SUPPORT BRKT. ASSY. - RIGHT
	0597-00012-0200	P.C. SUPPORT BRKT. ASSY. - LEFT
	0624-00902-0100	P.C. SUPPORT BRKT. - 12" (4 REQ'D.)
	0624-00902-0300	P.C. SUPPORT BRKT. - 2-1/2" (4 REQ'D.)
	0017-00101-0017	#6 x 1/2 HEX HD. WD. SCR. (20 REQ'D.)
	0017-00104-0037	3/4 O.D. x 3/16 I.D. x 1/16 STL. WASHER (20 REQ'D.)
	0017-00009-0419	PIN EXTRACTOR TOOL (PIN POPPER)

MIDWAY MFG. CO.
A BALLY COMPANY

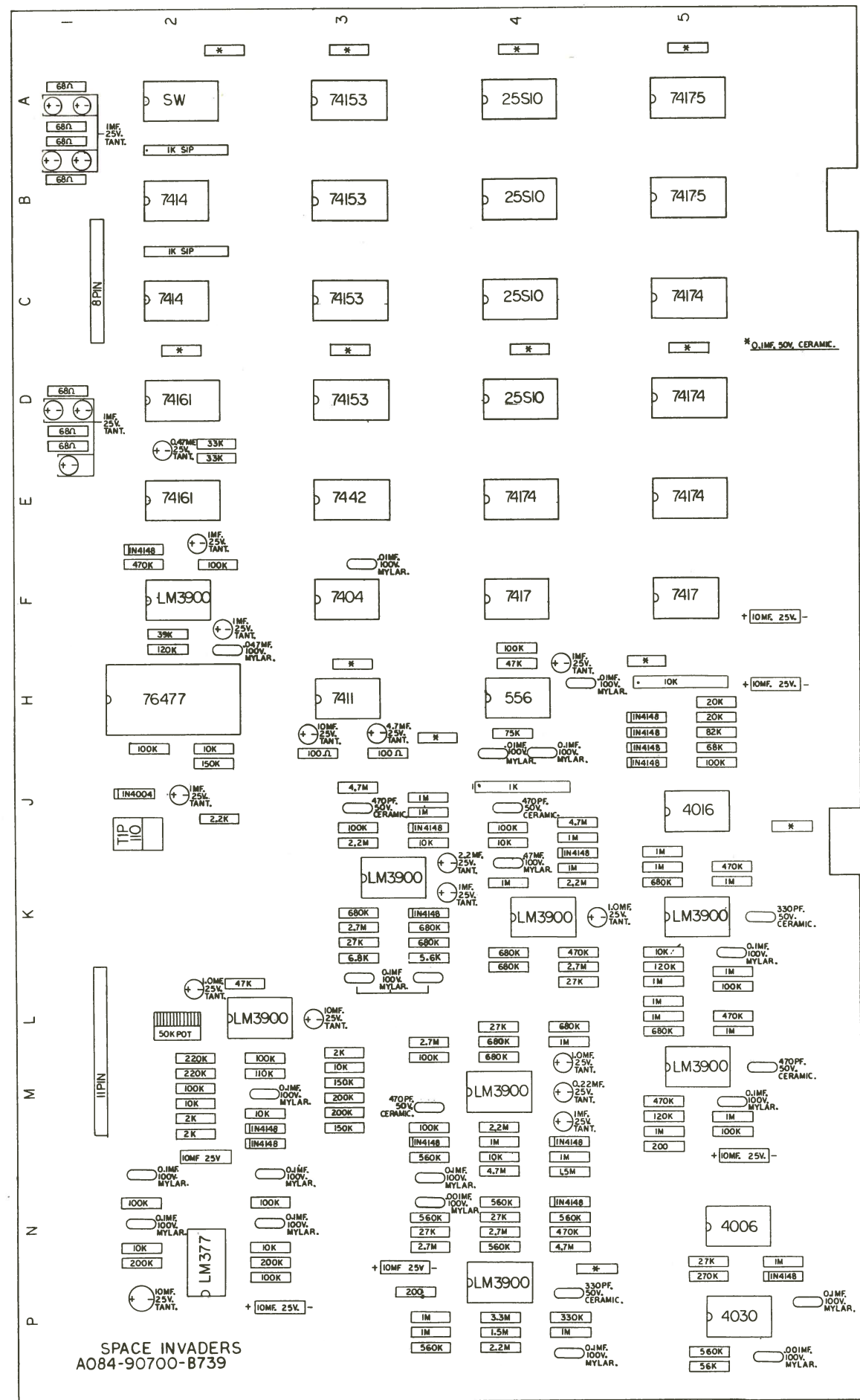

COMPONENT LAYOUT PART NO. M051-00739-A004

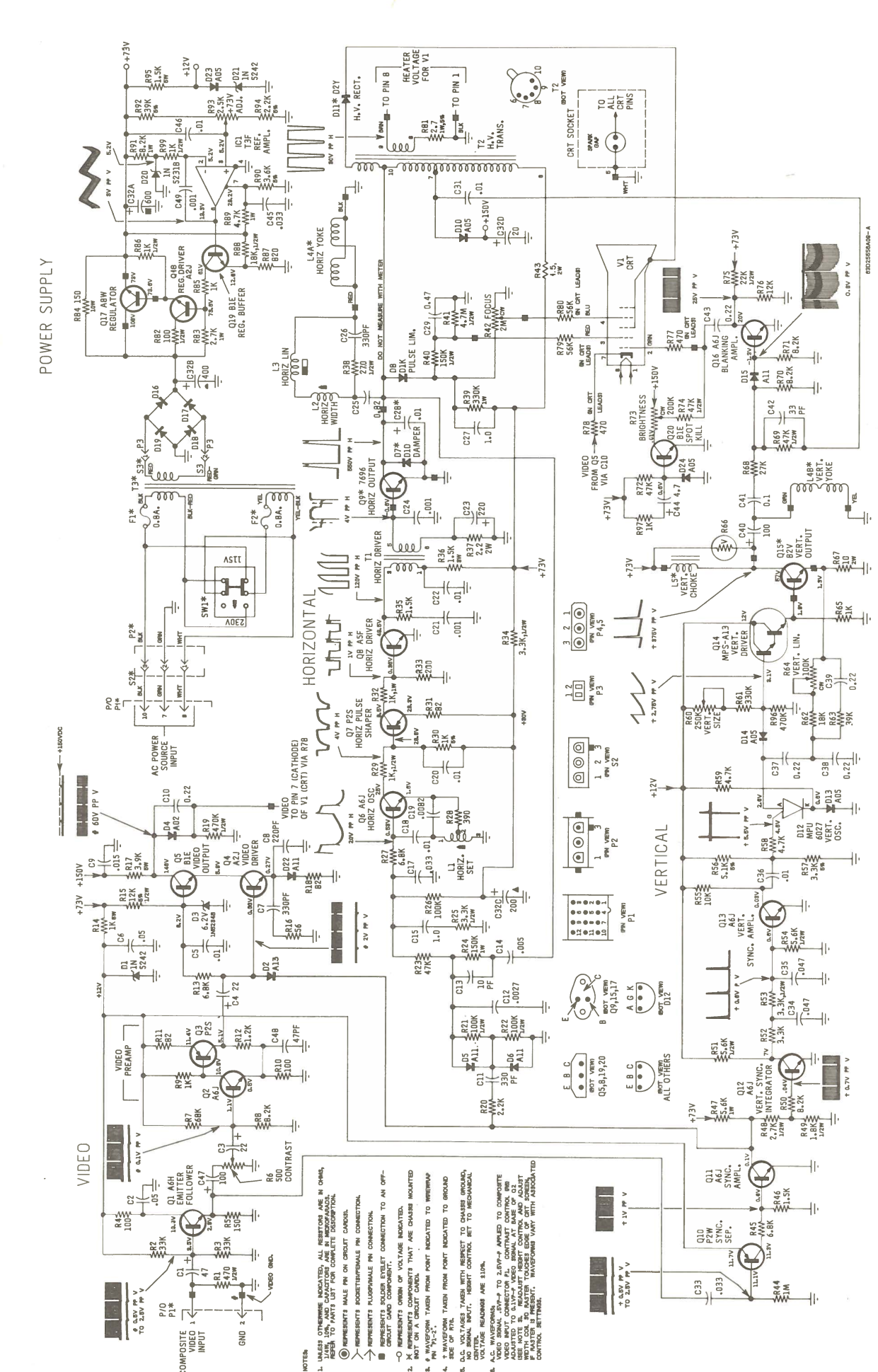
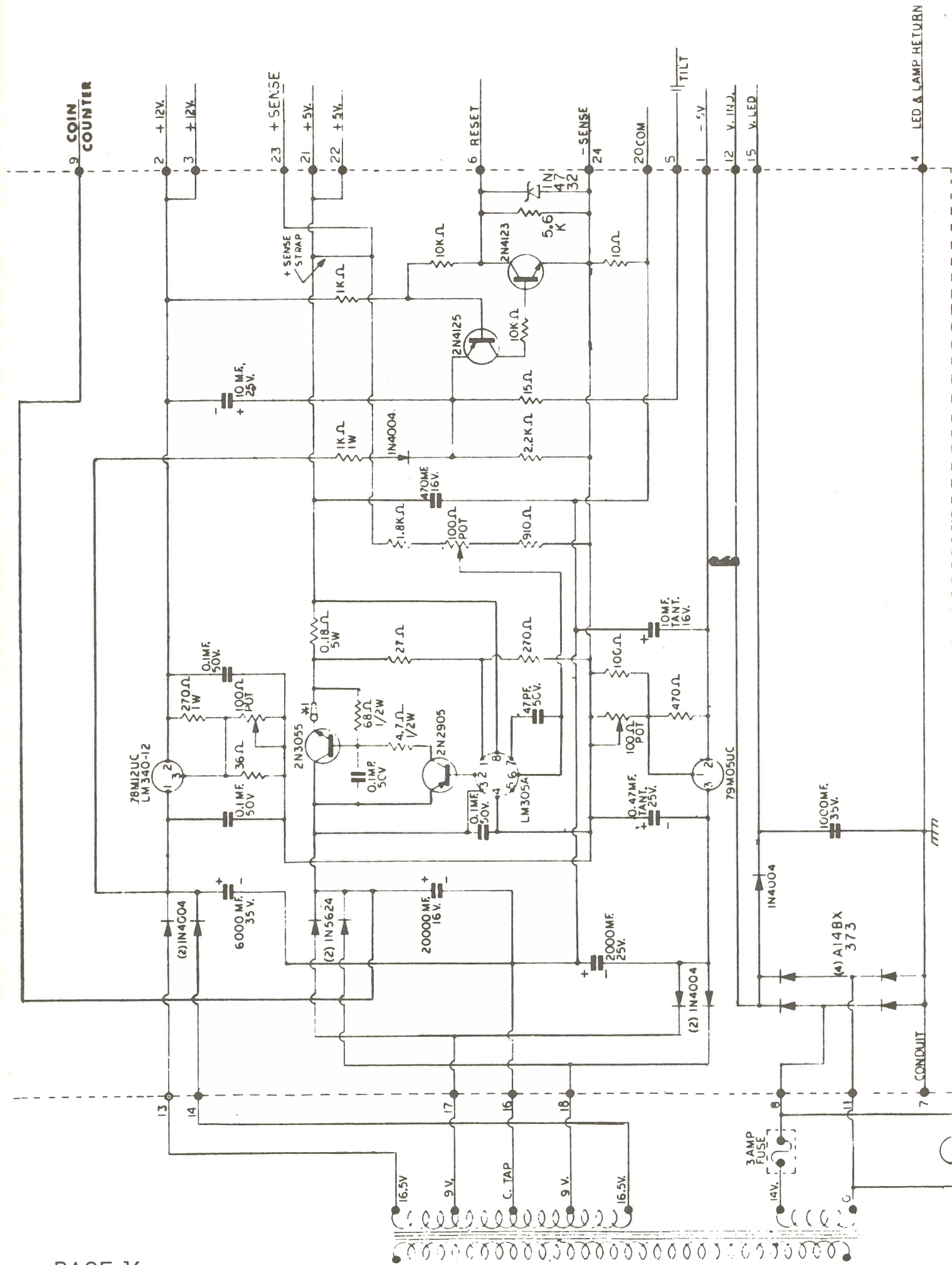

M5000-155, M7000-155 - Diagram Schematic

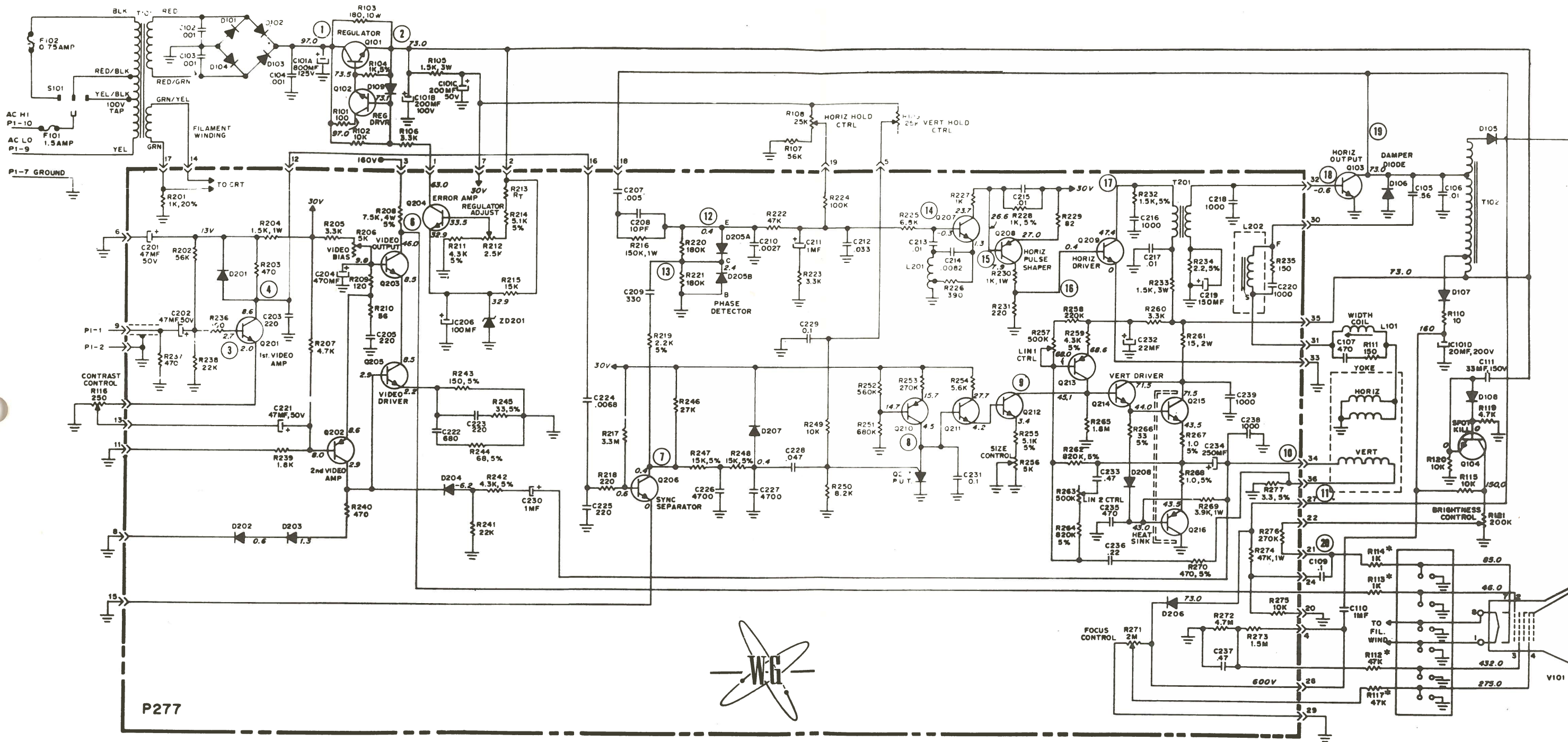

P277



WELLS - GARDNER ELECTRONICS

CORPORATION

2701 N. KILDARE AVE. • CHICAGO, ILL. 60639 • ALBANY 2-8220

TELEX 25-3286

NOTES:

1. VOLTAGE MAY VARY WITH CONTROL SETTING.
2. LINE VOLTAGE MAINTAINED AT 120VAC, 50/60Hz.
3. ALL D.C. VOLTAGES ±10% MEASURED FROM POINT INDICATED TO CHASSIS USING HIGH IMPEDANCE METER WITH NO SIGNAL INPUT. CONTRAST AND BRIGHTNESS CONTROLS AT MAXIMUM; ALL OTHER CONTROLS IN NORMAL OPERATING POSITION.
4. ○ - WITH INTERNAL NUMBER INDICATES LOCATION OF WAVE FORM READING.

NOTES:

- * INDICATES RESISTORS LOCATED IN PICTURE TUBE LEAD ASSEMBLY.
- RESISTANCE VALUES IN OHMS, 1/2 WATT, 10% UNLESS OTHERWISE NOTED. K-1,000 M-1,000,000
- CAPACITANCE VALUES OF 1 OR LESS ARE IN MICROFARADS. ABOVE 1 IN PICOFARADS UNLESS OTHERWISE NOTED.

MODEL No.
VI001-5734

REPLACEMENT PARTS LIST

CHASSIS PARTS

CAPACITORS

C101A, B, C, D	45X0558-001	800 μ F/125V, 200 μ F/100V 200 μ F/50V, 20 μ F/200V Electrolytic
C102, 103 104	80X0001-000	.001 μ F, GMV Z5U Cer. Disc.
★C105	342X5642-049	.56 μ F, 400V, 10% Polypropylene
★C106	46X0536-001	.01 μ F, 1200V, 5% Polypropylene
C107	80X0099-006	470 pF, Z5F, 10%
C109	342X1044-040	0.1 μ F, 400V, 20% Mylar
★C110	46X0540-002	1.0 μ F, 630V, 10% Polyester Film
C111	45X0515-032	33 μ F, 150V, Electrolytic

CONTROLS

R108, 109	40X0585-091	25k Ohm, Horiz. & Vert. Hold
R116	40X0585-090	250 Ohm, Contrast
R121	40X0585-092	200k Ohm, Brightness

COILS & TRANSFORMERS

★L101	9A2787-001	Coil, Width
★T101	53X0475-001	Transformer, Power
★T102	53X0474-001	Transformer, Flyback

RESISTORS

R101	340X3101-941	100 Ohm, 10%, 1/2W
R102, 115, 120	340X3103-941	10k Ohm, 10%, 1/2W
★R103	340X0181-341	180 Ohm, 10%, 10W, WW
R104	340X3102-931	1k Ohm, 5%, 1/2W
★R105	340X6152-341	1.5k Ohm, 10%, 3W, WW
R106	340X3332-941	3.3k Ohm, 10%, 1/2W
R107	340X3563-941	56k Ohm, 10%, 1/2W
R110	340X3100-941	10 Ohm, 10%, 1/2W
R111	340X3151-941	150 Ohm, 10%, 1/2W
R119	340X3472-941	4.7k Ohm, 10%, 1/2W

SEMICONDUCTORS

D101, 102 103, 104	66X0023-009	Rectifier, Silicon 500V 1N444B
★D105	66X0067-001	Rectifier Varo H1802
★D106	66X0068-001	Diode, Damper MR1-1600
D107	66X0053-001	Diode, 350V Amperex BA148
D108, 109	66X0046-001	Diode, Silicon FDH444
★Q101	86X0117-001	Transistor (NPN) 2N5632 Regulator
Q102	86X0071-001	Transistor (NPN) Reg. Driver MPSA06
★Q103	86X0118-001	Transistor (NPN) BU207 Hor. Output
Q104	86X0065-001	Transistor (NPN) D40N5 Spot Kill

MISCELLANEOUS

★F101	16X0171-001	Fuse Holder
★F102	16X0176-001	Fuse, 1.5 Amp, Slo-Blo 3AG
★	16X0175-001	Fuse, 0.75 Amp, Slo-Blo 3AG
★	13X1201-001	HV Lead & Recept. Assy.
★	28X0789-001	Spring, Dag, Grounding
★	9A2786-001	Deflection Yoke & Clamp
★V101	19VARP4	CRT (19V1001)
or	or	
★V101	22VATP4	CRT (22V1001)

★ Product Safety Device

REPLACEMENT PARTS LIST P277 CIRCUIT BOARD ASSY.

CAPACITORS

C201, 202, 221	45X0524-027	47 μ F, 50V, Electrolytic
C203, 205, 223, 225	80X0099-057	220 pF, 10%, Z5F, Cer. Disc.
C204	45X0524-053	470 μ F, 16V, Electrolytic
C206	45X0524-051	100 μ F, 50V, Electrolytic
C207	80X0099-192	.005 μ F, 20%, 1KV, Cer. Disc.
C208	80X0099-036	10 pF, 10%, 500V, Cer. Disc.
C209	80X0099-013	330 pF, 10%, 500V, Cer. Disc.
C210	349X4722-109	.0027 μ F, 10%, Mylar
C211	45X0524-023	1.0 μ F, 15V, Electrolytic
C212	349X3332-109	.033 μ F, Mylar
C213	46X0537-002	.01 μ F, Poly
C214	46X0537-003	.0082 μ F, Poly
C215	349X1032-109	.01 μ F, 10%, 100V Mylar
C216, 218, 220, 238, 239	80X0099-076	1000 pF, 10%, 500V, Cer. Disc.
C217	349X1032-209	.01 μ F, 10%, 200V, Mylar
C219	45X0524-052	150 μ F, 10V, Electrolytic
C222	80X0099-137	680 pF, 10%, 500V, Cer. Disc.
C224	349X6822-109	.0068 μ F, 10%, 100V, Mylar
C226, 227	80X0099-056	4700 μ F, 10%, 500V, Cer. Disc.
C228	349X4732-109	.047 μ F, 10%, 100V, Mylar
C229	349X1044-109	0.1 μ F, 20%, 100V, Mylar
C230	45X0515-014	1.0 μ F, 50V, Electrolytic
C231	349X1042-109	0.1 μ F, 10%, 100V, Mylar
C232	45X0524-026	22 μ F, 100V, Electrolytic
C233	349X4742-109	.47 μ F, 10%, 100V, Mylar
C234	45X0524-025	250 μ F, 100V, Electrolytic
C235	80X0099-006	470 pF, 10%, Z5F, Cer. Disc.
C236	349X2242-109	.22 μ F, 10%, 100V, Mylar
C237	46X0540-001	.47 μ F, 10%, 630V, Polyester Film

CONTROLS

R206, 256	40X0592-008	5k Ohm, Video Output, Size
R212	40X0585-093	2.5k Ohm, Reg. Adj.
R257, 263	40X0592-004	500k Ohm, Lin 1 & 2
R271	40X0585-094	2M Ohm, Focus

COILS & TRANSFORMERS

★L201	9A2788-001	Horiz. Osc.
★L202	9A2789-001	Horiz. Lin.
★T201	52X0126-001	Horiz. Driver

RESISTORS

R201	340X3102-954	1k Ohm, 20%, 1/2W
R202	340X3563-944	56k Ohm, 10%, 1/2W
R203, 237, 240	340X3471-944	470 Ohm, 10%, 1/2W
★R204	340X4152-843	1.5k Ohm, 10%, 1.0W
R205, 223, 260	340X3332-944	3.3k Ohm, 10%, 1/2W
R207	340X3472-944	4.7k Ohm, 10%, 1/2W
★R208	340X7752-733	7.5k Ohm, 5%, 4.0W
R209	340X3121-944	120 Ohm, 10%, 1/2W
R210	340X3560-944	56 Ohm, 10%, 1/2W
R211, 242, 259	340X3432-934	4300 Ohm, 5%, 1/2W
R213	43X0467-001	Thermistor
R214, 255	340X3512-934	5.1k Ohm, 5%, 1/2W
R215	340X3153-944	15k Ohm, 10%, 1/2W
★R216	340X4154-843	150k Ohm, 10%, 1.0W
R217	340X3335-944	3.3M Ohm, 10%, 1/2W
R218, 231	340X3221-944	220 Ohm, 10%, 1/2W
R219	340X3222-934	2.2k Ohm, 5%, 1/2W

★ Product Safety Device

RESISTORS (Cont'd.)

R220, 221	340X3184-944	180k Ohm, 10%, 1/2W
R222	340X3473-944	47k Ohm, 10%, 1/2W
R224	340X3104-944	100k Ohm, 10%, 1/2W
R225	340X3682-944	6.8k Ohm, 10%, 1/2W
R226	340X3391-944	390 Ohm, 10%, 1/2W
R227	340X3102-944	1k Ohm, 10%, 1/2W
R228	340X3102-934	1k Ohm, 5%, 1/2W
R229	340X3820-944	82 Ohm, 10%, 1/2W
★R230	340X4102-843	1k Ohm, 10%, 1.0W
R232	340X3152-934	1.5k Ohm, 5%, 1/2W
★R233	340X6152-743	1.5k Ohm, 10%, 3.0W
R234	340X5022-333	2.2 Ohm, 5%, 2.0W
R235	340X3151-944	150 Ohm, 10%, 1/2W
R236	340X3101-944	100 Ohm, 10%, 1/2W
R238, 241	340X3223-944	22k Ohm, 10%, 1/2W
R239	340X3182-944	1.8k Ohm, 10%, 1/2W
R243	340X3151-934	150 Ohm, 5%, 1/2W
R244	340X3680-934	68 Ohm, 5%, 1/2W
R245, 266	340X3330-934	33 Ohm, 5%, 1/2W
R246	340X3273-944	27k Ohm, 10%, 1/2W
R247, 248	340X3153-934	15k Ohm, 5%, 1/2W
R249, 275	340X3103-944	10k Ohm, 10%, 1/2W
R250	340X3822-944	8.2k Ohm, 10%, 1/2W
R251	340X3684-944	680k Ohm, 10%, 1/2W
R252	340X3564-944	560k Ohm, 10%, 1/2W
R253, 276	340X3274-944	270k Ohm, 10%, 1/2W
R254	340X3562-944	5.6k Ohm, 10%, 1/2W
R258	340X3224-944	220k Ohm, 10%, 1/2W
★R261	340X5150-843	15 Ohm, 10%, 2.0W
R262, 264	340X3824-934	820k Ohm, 5%, 1/2W
R265	340X3185-944	1.8M Ohm, 10%, 1/2W
R267, 268	340X3010-934	1 Ohm, 5%, 1/2W
R269	340X4392-843	3.9k Ohm, 10%, 1/2W
R270	340X3471-934	470 Ohm, 5%, 1/2W
R272	340X3475-944	4.7M Ohm, 10%, 1/2W
R273	340X3155-944	1.5M Ohm, 10%, 1/2W
★R274	340X4473-843	47k Ohm, 10%, 1.0W
R277	340X3033-934	3.3 Ohm, 5%, 1/2W

SEMICONDUCTORS

D201, 202, 203, 204, 207, 208	66X0046-001	Diode, Silicon FDH444
D205A, 205B	66X0066-001	Diode, Dual, MSD6102
D206	66X0054-002	Diode, RCA D2102SF
Q201, 205, 206	86X0113-001	Transistor (NPN) 2N3904
Q202, 208	86X0114-001	Transistor (PNP) 2N3906
Q203	86X0071-001	Transistor (NPN)
Q204, 212	86X0071-001	Transistor (NPN) MPSA06
Q207, 211	86X0058-002	Transistor (NPN) MPSA20
Q209	86X0116-001	Transistor Horiz, Driver (NPN) 2N6557
Q210	86X0066-001	Transistor (PNP) MPSA70
Q213	86X0072-001	Transistor (PNP) MPSA56
Q214	86X0073-001	Transistor (NPN) MPSU07
Q215	86X0074-001	Transistor (NPN) 2N5192
Q216	86X0075-001	Transistor (PNP) 2N5195
Q217	86X0070-001	Transistor (P.U.T.) MPU131
ZD201	66X0040-004	Diode, Zener 31V

MISCELLANEOUS

38A5395-000	Pix Socket & Connector Assy.
-------------	------------------------------

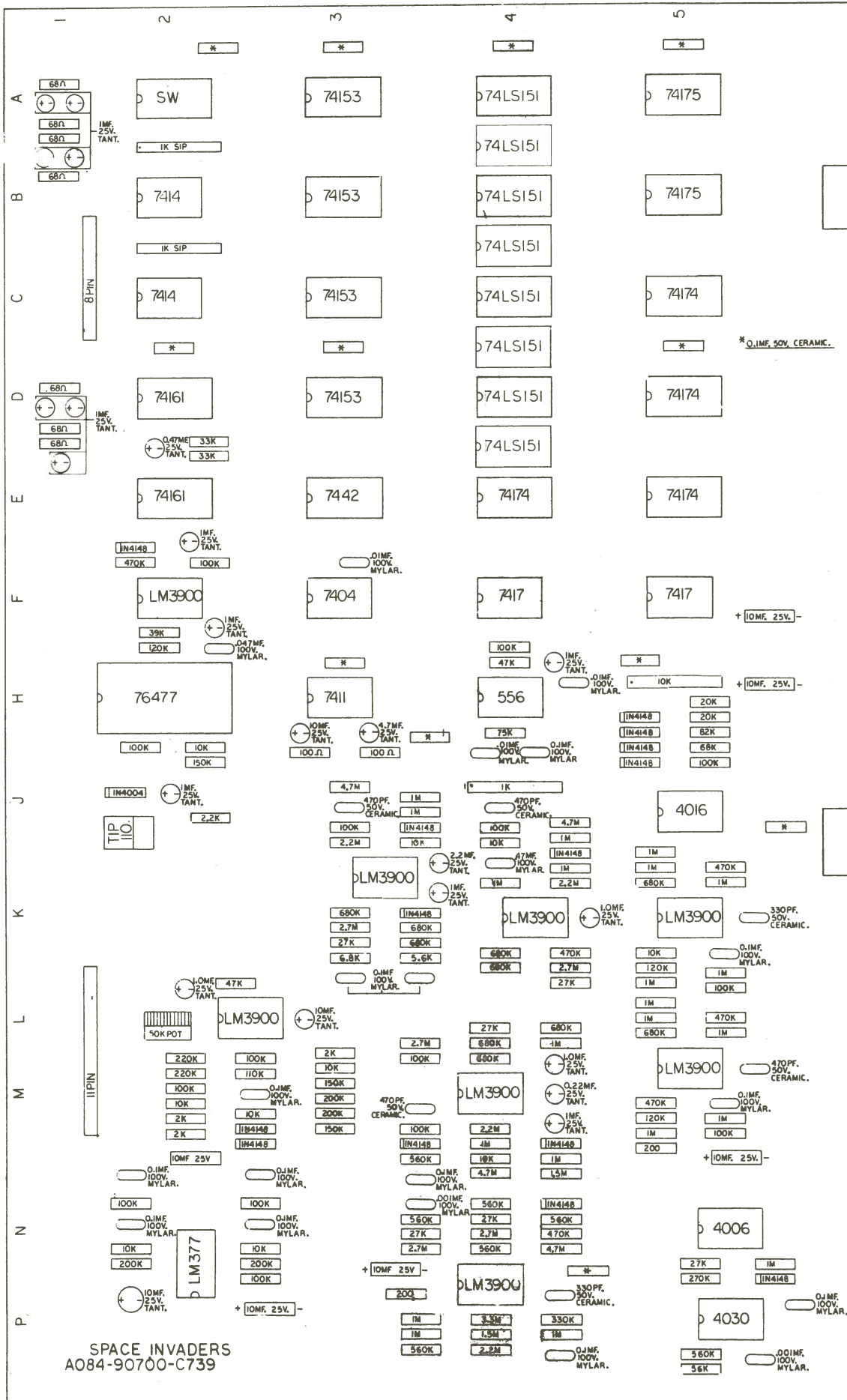

COMPONENT LAYOUT PART NO. M051-00739-B004

1 BONUS LASER BASE AWARDED AT 1500 POINTS

ADJUSTMENT SWITCHES			
COIN INFORMATION DISPLAYED ON SCREEN		SW. 1	
		ON	
COIN INFORMATION IS NOT DISPLAYED ON SCREEN		OFF	
BONUS MISSILE BASE			
BONUS BASE AWARDED AT 1000 PTS.		SW. 2	
		OFF	
BONUS BASE AWARDED AT 1500 PTS.		ON	
NUMBER OF BASES PER GAME			
		SW. 3	SW. 4
3	BASES	ON	ON
4	BASES	OFF	ON
5	BASES	ON	OFF
6	BASES	OFF	OFF
* SWS 5, 6, 7 AND 8 ARE NOT USED. SHOULD BE ON			
			M051-00739-A010

OPERATOR: PLEASE COMPLETE AND RETURN

SPACE INVADERS

WAS THIS GAME RECEIVED IN GOOD CONDITION

YES

REMARKS: (Adjustments Necessary or Damage)

NO

NAME OF GAME

SERIAL NO.

RECOMMENDATIONS AND SUGGESTED IMPROVEMENTS

COMPANY NAME

STREET

CITY

STATE

ZIP NO.

FORM-00041-0877